

Design of the Robot-Cub (iCub) Head

Ricardo Beira*, Manuel Lopes*, Miguel Praça*, José Santos-Victor*, Alexandre Bernardino*
Giorgio Metta†, Francesco Becchi‡, Roque Salterén§

*Instituto Superior Técnico, Institute for Systems and Robotics, Lisbon, Portugal

Contact Email (J. Santos-Victor): jasv@isr.ist.utl.pt

†Lira Lab, DIST, University of Genova, Italy

‡Telerobot SRL, Italy

§DISAM - Universidad Politécnica de Madrid, Spain

Abstract— This paper describes the design of a robot head, developed in the framework of the RobotCub project. This project goals consists on the design and construction of a humanoid robotic platform, the iCub, for studying human cognition. The final platform will be approximately 90cm tall, with 23 kg and with a total number of 53 degrees of freedom.

For its size, the iCub is the most complete humanoid robot currently being designed, in terms of kinematic complexity. The eyes can also move, as opposed to similarly sized humanoid platforms.

Specifications are made based on biological anatomical and behavioral data, as well as tasks constraints. Different concepts for the neck design (flexible, parallel and serial solutions) are analyzed and compared with respect to the specifications. The eye structure and the proprioceptive sensors are presented, together with some discussion of preliminary work on the face design.

I. INTRODUCTION

This paper describes the design and construction of the iCub robotic head/neck system. It is included in the European Project RobotCub, a large and ambitious project of embodied cognitive systems [1].

The RobotCub project has the twin goals of (1) creating an open and freely-available humanoid platform, iCub, for research in embodied cognition, and (2) advancing our understanding of cognitive systems by exploiting this platform in the study of cognitive development. To achieve this goal we plan to construct an embodied system able to learn: i) how to interact with the environment by complex manipulation and through gesture production & interpretation; and ii) how to develop its perceptual, motor and communication capabilities for the purpose of performing goal-directed manipulation tasks. iCub will have a physical size and form, similar to that of a two year-old child, as shown in Figure 1 and will achieve its cognitive capabilities through artificial ontogenic codevelopment with its environment.

In recent years, the need for new generations of robots has drifted from industrial automation to human friendly robotic systems, able to routinely interact with humans in environments such as offices, homes and hospitals. The study of humanoid robots is particularly relevant for this type of interaction because of anthropomorphism, friendly design, applicability of locomotion, behavior within the human living

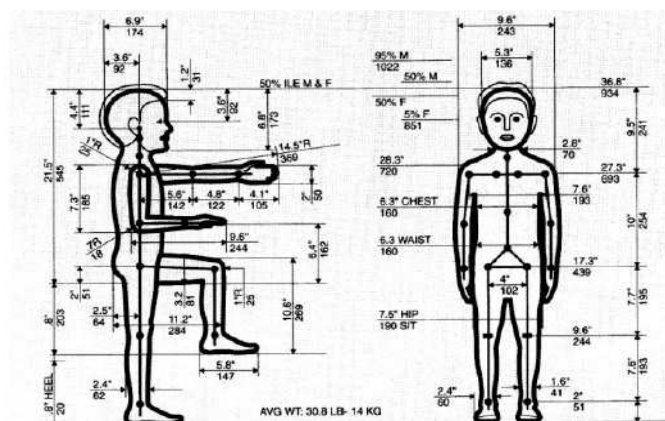

Fig. 1. Approximate size targeted for the iCub [2]

environments, small size and so on. In fact, one reason for the (relatively) small size of humanoid type robotic platforms is safety: striding about in homes, a small robot is less likely to harm people by falling on them. Another reason is that shorter limbs and appendages are easier to move and control. To meet these demands, several humanoid robots have been developed in these years.

Several small size humanoid robots are already available. Qrio [3] (from Sony), was designed to interact and entertaining people by means of motion, speech and vision. Its remarkable motion capabilities are driven by 38 joints (4 on the neck, fixed eyes) each controlled by a separate motor. Qrio senses its own motion through accelerometers in the torso and feet. It is 58cm height and weighs approximately 6.5 Kg.

Honda engineers created ASIMO [4] that, with 26 degrees of freedom (2 on the neck, fixed eyes), can walk and perform some tasks much like a human. It is 120cm height and weighs about 52Kg. It was the first robot able to climb stairs and run.

The PINO project [5] started with the goals of: developing a platform for research on perception and behaviour, using multiple perception channels and many DOFs; investigating robot design that are well accepted by the general public and develop affordable humanoid platform using off-the-shelf components and low-precision materials. The size of the robot

is carefully designed to be the size of the 1.5 year-old kids (height 70cm). It has 26 DOFs and 4.5Kg of weight.

Another miniature humanoid robot is Fujitsu's HOAP-2 [6]. This platform has been programmed to perform movements from the Chinese martial art taiqi, Japanese Sumo wrestling stances as well as to aid to robotics research. This robot's weight is less than 7kg and its height is 50cm. It has a total of 25 DOFs (2 in the neck, the eyes are fixed).

The iCub will have head, torso, two arms/hands and two legs. The legs will be used for crawling but, possibly, not for biped walking. This will allow the system to explore the environment not only by manipulating objects but also through locomotion. For this reason, it is particularly important to equip the iCub with enough degrees of freedom to allow transition between sitting and crawling posture, as well as to look down while manipulating objects lying on the floor. In the current version of the design, the iCub is about 90cm tall, weighs 23 kg and has a total of 53 degrees of freedom organized as follows: 7 for each arm, 8 for each hand, 6 for the head, 3 for the torso/spine and 7 for each leg.

The eye-head sub-system will include basic visual processing primitives, as well as low-level oculomotor control, visual, inertial and proprioceptive sensors. The iCub will have two arms with the motor skills and sensory components required for dexterous manipulation. From the control point of view, reaching and grasping primitives will be implemented together with primitives to acquire tactile and proprioceptive information. It is expected that most of the actuators of the hand will be located in the forearm. The hands will be underactuated to save space, power consumption, and cost. This is implemented by means of rigid mechanical couplings, such as single tendon to bend two joints of a finger alike, or by an elastic coupling of the joints.

Most existing humanoid systems have a simplified head with a small number of degrees of freedom. In our case, the interaction with other robots or individuals is very important, justifying the need to include a greater kinematic complexity, while meeting very stringent design constraints, in terms of weight and size. This paper main contributions are:

- Review of anatomical data for neck and eyes
- Derivation of the specifications for a small size robotic head, based on data from humans.
- Design of small size serial mechanism with impact protection
- Description and comparative analysis of several solutions for the (small size) neck design: parallel neck, spring like mechanism based on flexible spine and a serial solution.

One point worth stressing is that the iCub platform is designed to serve as a research tool for embodied cognition, visuomotor coordination, and development. Hence, the project consortium includes teams of engineers as well as psychologists, neuroscientists and biologists. The final mechanical design will be made available to researchers worldwide and released under a General Public License (GPL).

II. MECHANISM SPECIFICATIONS

In this section we summarize some of the human anatomical data considered in the design and the assumptions we made to transform these specifications to our robot.

A. Anatomical Data

1) *Neck*: The human neck has a very complex muscular and skeletal system, with more than twenty muscles ([7], [8], [9], [10]) and ten bones ([7], [11]). The head has more complexity if we consider the mouth, the eyes and the facial expressions.

The neck is constituted by seven vertebrae and the atlas that supports the skull. The vertebrae can be modeled as flexible springs giving flexion/extension and adduction/abduction motion. The atlas bone gives the possibility of rotating the head and an upper flexion/extension movement. All these bones are actuated by muscles in a differential way. For every motion, agonistic and antagonistic muscles are used, each having a flexion, rotation and abduction function, e.g. the *sternocleidomastoid* muscle. Some of the muscles begin in the spine while others continue through in the neck.

The neck kinematic model has been the object of studies in human biomechanics, for the analysis of injuries caused by impacts, sports training, etc. The most standard model of the human neck has four degrees of freedom ([12], [13], [14]).

2) *Eyes*: Each human eye has six muscles. As it is a globe inside a socket three motions can be considered, abduction/adduction, elevation/depression and rotation. The muscles have combined actions to achieve these motions, as described in Table I. Each eye is completely independent of the other.

Muscle	Action
Superior rectus	Elevates, adducts, and rotates eyeball medially
Inferior rectus	Depresses, adducts, and rotates eyeball laterally
Lateral rectus	Abducts eyeball
Medial rectus	Adducts eyeball
Superior oblique	Abducts, depresses, and medially rotates eyeball
Inferior oblique	Abducts, elevates, and laterally rotates eyeball

TABLE I
EYE MUSCLES ACTION. (FROM www.eyegk.com)

The human oculomotor system combines several basic movements: saccades, smooth pursuit, vergence, vestibulo-ocular reflex, optokinetic reflex, microsaccades and accommodation.

Saccadic and smooth pursuit eye movements occur when the eyes pursue an object. During smooth pursuit, the eye tries to match the (angular) speed of the tracked target, usually at relatively low speeds (up to 30°/s). Saccadic eye movements are high speed jumping movements, in the range of a few hundreds degrees per second. The saccadic eye movement occurs when the eye ball movement is not able to pursue an object or when the human searches outside of the view.

Apparently, the role of the microsaccadic movements is to ensure that the photo-sensitive cells are stimulated in a persistent manner. The accommodation reflex is responsible for focusing. In the artificial system, these two behaviors

are implemented at the camera level. The vestibulo-ocular behavior is responsible for stabilizing the image when the head makes very fast motions, relying on estimates of angular acceleration from the vestibular system.

Table II presents the range of movements for each joint, [15] and the eye/neck speed for human adults during saccadic movements with 2.5, 5, 10, 40, 60 degrees amplitude. The saccade speed increases with the motion amplitude. Hence, the speed during small amplitude saccades resemble those of smooth pursuit. These data also show how the effort is divided amongst eye and neck degrees of freedom when some redundancy exists (e.g. eye and neck pan movements). This information has been used for the design of the iCub head specifications.

Adult values Head weight: 4.5 – 5Kg		Range [$^{\circ}$]	Velocity [$^{\circ}/s$]		Acceleration [$^{\circ}/s^2$]	
			min	max	min	max
eyes	pan	90	166	850	16000	82000
	tilt	80				
neck	pan	110	23	352	330	3300
	tilt	90				
	swing	80				
Neck/eye (pan) ratio			14%	41 %	2%	4%

TABLE II

ANTHROPOMORPHIC DATA ([16], [15]), SHOWING THE MOTION AMPLITUDE AND SPEED FOR SOME DEGREES OF FREEDOM IN THE HUMAN EYE/NECK SYSTEM.

B. Robot Head Specifications

The initial specifications for the iCub are quite demanding. The total head weight should not exceed 1.5 Kg and the size is that of a 2 year old child. The head is 13.6 cm wide, 17cm long and 17.3cm deep. The neck is 7cm wide and 9cm long. For modularity, we divide the head in the neck and eye subsystems.

In order to guarantee a good representation of the human movements, the iCub head contains a total of 6 DOFs: neck pan, tilt and swing and eye pan (independent) and tilt (common) as shown in Figure 2. Facial may be included in a later stage. We are studying the use of a minimal set of facial expressions (implying the smallest possible number of motors or moving parts) to convey information about the robot's emotional status.

Although the human neck has four dof, the upper neck flexion/extension was ignored because of space/weight limitations. For most tasks this motion is not necessary, since orienting the eyes toward a scene point requires only two degrees of freedom. There is still some redundancy in the neck to avoid obstacles, occluders or to choose better viewpoints.

The eyes cyclotorsion was ignored because it is not useful for control, and similar image rotations are easily produced by software. The elevation/depression from both eyes is always the same in humans, in spite of the existence of independent muscles. Similarly, a single actuator is used for the robot eyes elevation (tilt). Eye vergence is ensured by independent

motors. Figure 2 shows the final chosen kinematics, that allows all basic ocular movements.

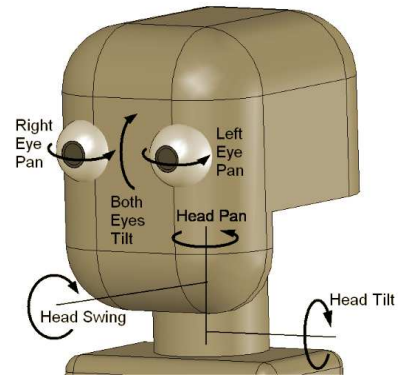

Fig. 2. Illustration of the Head degrees of freedom. There is a total of six degrees of freedom, three for the neck and three for the eye system (facial expressions are not included).

One of the most critical design steps is that of defining the desired velocities and accelerations for the various joints. This will directly impact on the choice of motors and, therefore, on size/weight constraints.

Data regarding accelerations, velocities and joint range of the oculomotor system of human babies are not available, and very few studies exist in the literature of psychology or physiology. This section explains how we determined the anthropomorphic data and specifications for the iCub robot head. Overall, the iCub dimensions are those of a two-year-old human child, and it is supposed to perform tasks similar to those performed by human children.

In Table II there are two key observations for the iCub head design. First, we will use the smaller range of saccadic speeds as a reference, since (i) these are adult data and children have significantly smaller speeds and (ii) small amplitude saccades are close to smooth pursuit movements, which are far more frequent during the robots normal operation. Secondly, we will use the ratio between neck/eye velocity (14% – 41%) and acceleration (2% – 4%) as an important design parameter.

Using this information, and hypothesizing a trapezoidal motion profile for the eye movements (as axis control boards usually specify), we can compute all joint accelerations, as shown in Table III.

		Range [$^{\circ}$]	Max Vel. [$^{\circ}/s$]	Acceleration Full range		
				acc.[$^{\circ}/s^2$]	T_{tot} [s]	mean vel
eyes	pan	90	180	1440	0.625	144
	tilt	80	160	1280	0.625	128
neck	pan	110	90	295	1.528	72
	tilt	90	73.6	241	1.528	59
	swing	80	65.5	214	1.528	52

TABLE III

COMPUTED SET OF ANGULAR SPEED AND ACCELERATION FOR THE VARIOUS DEGREES OF FREEDOM OF THE ROBOT CUB HEAD.

We set the eye pan maximum speed to $180^{\circ}/s$ and assumed

that the neck pan reaches half that speed. We further consider that 20% of the time is used for acceleration and another 20% for slowing down. The remaining part of the trajectory is executed at maximum speed. In addition we considered that the neck tilt and swing dofs would take the same time as the neck pan to move its entire motion range. These specifications were used for the head design.

III. MECHANICAL DESIGN

The Mechanical Design of the iCub head is divided in three major parts: Neck Mechanism, Eyes Mechanism and Cover (face). During the design process, we used the specifications derived previously and adopted the following desirable characteristics/criteria:

- DOFs., range of motion, joint speed and torque according to detailed specifications.
- Compactness and weight, to meet all the desired specifications ($< 1.5Kg$),
- Modularity and simplicity of the structure to facilitate maintenance and assembly,
- Self-contained to facilitate integration with the other parts of the robot,
- Robustness, to resist the efforts suffered during its working period
- use of standard mechanical components

In the following sections we describe the various possibilities considered for each component.

A. Neck Mechanism

For the Neck Mechanism, we have analyzed, developed and prototyped 3 different solutions (Figure 3).

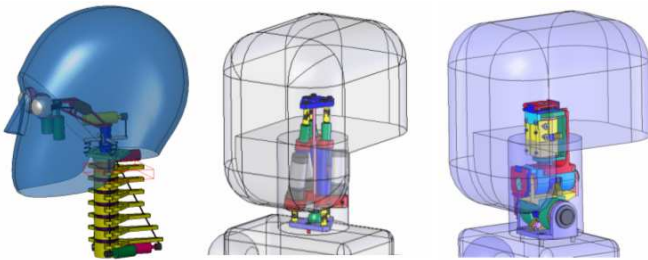

Fig. 3. Three alternative solutions for neck mechanism

1) *Spring Neck*: Inspired by the flexibility of the human neck, one design concept included a spring, Figure 4, actuated with 3 cables separated 120° apart, producing a spherical motion of the head. Unfortunately, the center of rotation is very difficult to estimate because it depends on the spring size, elasticity and on the topology of the actuators. A final motor is included on top, assuming the function of atlas, for the head pan. Another problem with this design is that motors would have to be placed in the robot chest, jeopardizing the design modularity.

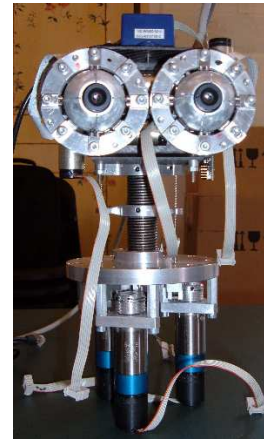

Fig. 4. Prototype of robot head with spring-based neck.

2) *Parallel Neck*: To be modular and self-contained, the head structure must support a large number of mechanical and electrical components. On the other hand, high torque motors are required to drive the cameras, in particular to achieve the velocity of saccadic eye movements. So, to satisfy both (conflicting) requirements, an interesting solution for the robot neck structure is based on a parallel mechanism. Parallel mechanisms have remarkable characteristics such as high precision, high load capacity, high rigidity, interior space for cabling and very easy solutions for the inverse kinematics. Also, since all motors are fixed on the base, the inertia of the moving part is relatively small.

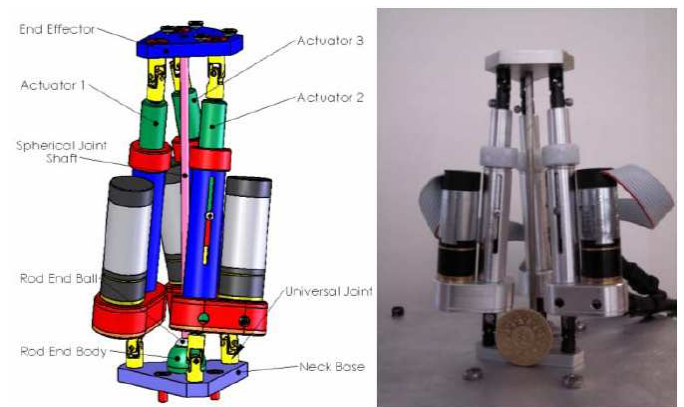

Fig. 5. CAD Model of the Parallel Neck and prototype

In this architecture, the platform and the base are joined by a passive spherical pair. The platform orientation is controlled by three legs of type UPS (U, P and S stand for universal joint, prismatic pair and spherical pair, respectively), the prismatic pair being the actuated joint. This parallel neck has the advantage of being a three dof mechanism (spherical motion) and has the drawback of having reduced workspace because of the passive spherical pair [17], [18], [19].

For such a small size neck ($9cm \times 7cm$), we had to design our own linear actuators, with the mechanism moved by three Linear Ball Screw Actuators (Fig. 6). Comparing

with other solutions, this type of actuators offers a good compromise between size, controllability and load capacity. The mechanical structure of these components is shown in Figure 6. One of the main disadvantages for this concept is that it is very difficult to avoid the interference between the various parts, for such large movements (motion range). Also, the achieved velocities are slightly smaller than the original specifications.

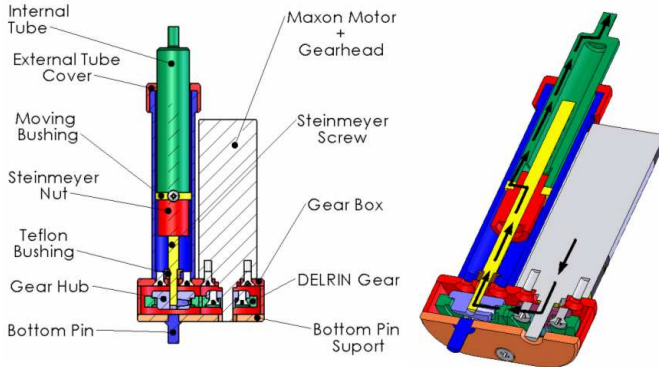

Fig. 6. Ball Screw Linear actuator

3) *Serial Neck*: The third solution tested was of a serial manipulator (Figure 7) with three degrees of freedom, placed in a configuration that best represents human neck movements. We used DC micromotors (Faulhaber [20]) with planetary gearheads. In spite of its simplicity, the mechanism is very robust, easy to control and highly performing, meeting all the specifications. For these reasons, this was the final choice adopted for the iCub head neck.

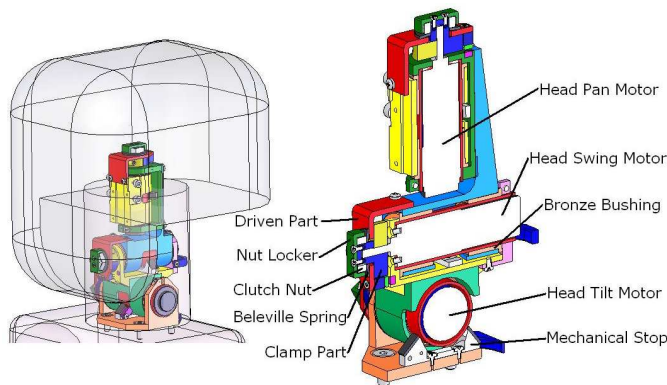

Fig. 7. CAD Model of Serial Mechanism

One major requirement of this system is the resilience to damage of the robot units since the learning (cognition, understanding, and behavior) of the robot will involve potentially the many “falls” and “accidents” experienced by any child learning to cope with the world. This may be particularly critical for the delicate head and neck mechanisms.

To overcome this problem, each joint in the serial neck mechanism uses an overload clutch system (Figure 8). Each Overload Clutch System is essentially composed by a driven

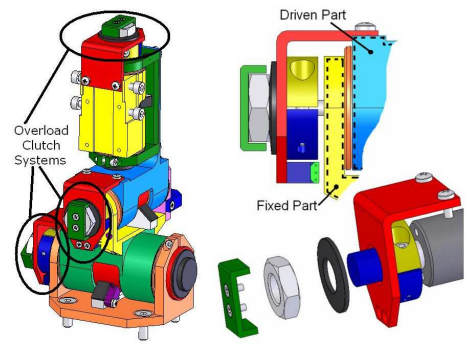

Fig. 8. Clutch based overload protection system.

component, which is fixed to the rotating part of the mechanism, a nut, a *belleville* spring and a clamp device, fixed to the motor shaft. When the *belleville* spring is compressed by the nut, the driven component is smashed against the clamp device, producing enough friction to transmit the movement of the joint. In an overload situation, this friction will not be enough and the driven component will slide, protecting the motor gearbox from the impact.

The overload clutch system increases the robustness of the mechanism, giving it the possibility to fall on the floor and suffer different kind of impacts and efforts during its interaction with the external world.

B. Eyes Mechanism

The eyes mechanism has three degrees of freedom. Both eyes can pan (independently) and tilt (simultaneously). The pan movement is driven by a belt system, with the motor behind the eye ball. The eyes (common) tilt movement is actuated by a belt system placed in the middle of the two eyes. Each belt system has a tension adjustment mechanism.

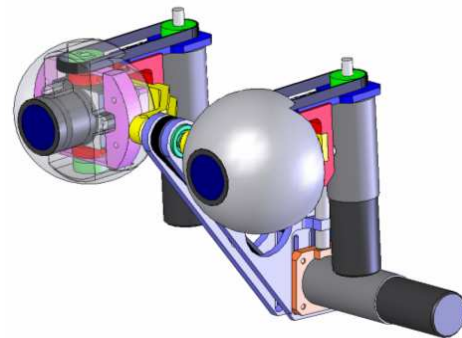

Fig. 9. eye mechanism

For the necessary acceleration and speed, we have chosen Faulhaber DC micromotors, equipped with optical encoders and planetary gearheads. The final available torque and speed are comfortably larger than the required specifications.

C. External Cover

Because this robot is designed to be engaged in social interaction, one of the main concerns in the design is the

understanding of which facial features dimensions contribute more to the communication with humans. This research is important for the fields of human-computer interaction and the impact of design on this field has to be well understood. General dimensions of the different parts of the robot and the total number of facial features are some examples that influence heavily the perception of human-ness in robots. The external cover must also ensure the protection of the head mechanisms, absorbing the external efforts, suffered by the robot during operation. Figure 10 shows the first prototype of the iCub face, where a “toy-like” concept was selected for the design.

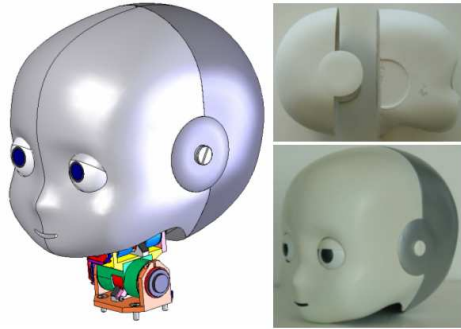

Fig. 10. Preliminary Design of the iCub face, integrated with the mechanism.

IV. SENSORS AND ELECTRONICS

As an open physical platform for embodied research, that can be used by the research community from different types of science fields (like physiology, cognitive robotics and perceptual science), the iCub mechatronics system cannot be very complex. So, in order to guarantee easy assembly and maintenance procedures, the mechanical system architecture is also completely modular, in such a way that we can remove and replace a certain module, without having to disassemble the entire structure. Figure 11 shows the head with the integration of the electronics/sensors.

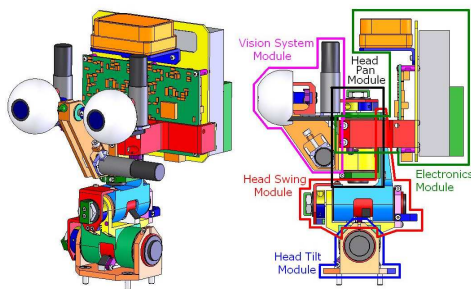

Fig. 11. Modular Architecture of the System

To allow the robot to interact with other people and to have all desired behavior several sensors were applied. For vision, the main sensory modality, two DragonFly cameras [21] with VGA resolution and 30 fps speed. These cameras are very easy to integrate because the CCD sensor is mounted on a remote

head, connected to the electronics with a flexible cable. In this way, the sensor head is mounted in the ocular globe, while the electronics are fixed to a non-moving part of the eye-system.

The inertial sensor is very important to have the vestibulo-ocular reflex and to detect the overall posture of the body. We have selected the from MTi sensor, from Xsens Technologies B.V. Several microphones are installed around the head to be able to locate the sound source of people in the surrounding area.

All motor control boards will be specially designed to fit in the size constraints of the robot. They are all integrated in the head and connect to the remote computer with CAN-bus. To measure the head position (kinesthetic information), the motors have magnetic encoders, for calibration purposes and noting that the protection system drift in case of overload condition, absolute position sensors were applied to each neck joint.

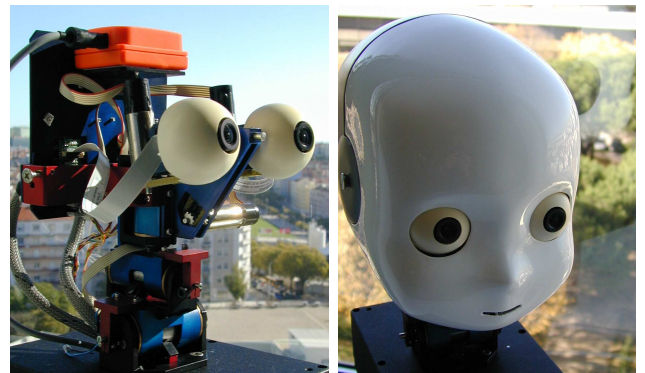

Fig. 12. Final prototype of the iCub head. Height from base to top is 11cm. Electronics are not shown in the picture. Right: prototype with face mounted.

V. TESTS

Several tests were made to evaluate the functional use of the designed head. Every joint was tested, in the worst case scenario, to verify that velocity and acceleration specification where met. Several other demos/tests were created to verify the coordination between the sensors and actuators in the system.

Object tracking - An object moving in front of the system is considered to be successfully tracked if it is near the center of both images. Since this is a 3 dof task and the robot has 6 dof, some extra criteria should be used to control all dof. The eye’s 3 dof are directly controlled with a visual servoing mechanism, having the image positions of the object as feedback. The neck is then controlled in order to maintain the eyes as far as possible for their joint limits. This choice is motivated by biological behavior. The rationale for having the eyes in a comfortable position is that they will be readily available to track the object in any direction even if it moves very fast.

Balancing - The inertial sensor provides a reliable measure of the orientation of the head and also the angular velocities. This information can be used to keep the head always in a upright position. The inclination information controls directly

the first 2 dof of the neck. The angular velocity is used to create an artificial vestibular reflex, that in presence of a fast motion keeps the eyes looking in the same direction.

Sound localization - Using information about the time-difference, sound energy level and spectral power at some special frequencies, it is possible to localize sound sources with the iCub head. This algorithm is very reliable for the horizontal plane and can be used either with a closed or an open loop controller. Please refer to <http://vislab.isr.ist.utl.pt> for videos of these demos.

VI. CONCLUSIONS/FUTURE WORK

We presented the design for a robot head of a small size humanoid robot. This humanoid robot - the iCub - is meant to be used as a research tool for human cognition and publicly distributed worldwide. The iCub neck has 3 dof and the eyes 3 dof, the more complex mechanism for similarly sized robots, where the eyes are usually fixed.

The specifications were derived from human anatomical and behavioral data. As some of these data are not available (and even less data can be found for children), extra assumptions had to be made. We referred to typical tasks the robot should do and the ratio between neck and eyes velocities/acceleration in humans. The final kinematic has three dof for the neck. For the eyes, three degrees of freedom (independent vergence, common tilt) were considered. Other movements like cyclo-torsion can be dealt with at the camera level.

A first solution for the neck was a spring mechanism mimicking the human anatomy. It has good kinematic capabilities but low repeatability and precision, due to the spring.

A very small 3 dof parallel actuator was proposed as our second design. It is very compact and delivers high torque. Due to extremely reduced size, a home-made linear actuator was designed. It meets all the specifications, except the desired range of motion. Although this could be a very attractive solution if we could afford using a 20% bigger neck, self-interference of the mechanical parts precluded its use at the current stage.

The design that met all the specifications was a serial mechanism. It has a clutch system to overdrive protection. All motors are similar and the assembly is modular.

The lightweight eye system has three dofs, consisting of independent eye pan and a common tilt. The head is equipped with additional sensors, like an inertial sensor for the vestibular system, kinesthetic information from encoders, absolute position sensors in the neck and embedded controllers. The overall weight is below 1.5Kg (all motors included) and the size is that of the head of a 2 year old child. A first prototype of the iCub face was designed and built.

The head has been mounted and tracking experiments were done to assess the performance of the mechanism, that is quite encouraging. As future work other experiments will be done, including the use of the microphones and the inertial signals. A re-formulation of the parallel mechanism may be conducted to increase the range of motion.

The iCub final mechanical design will be freely available to researchers worldwide, and released under General Public License (GPL) - www.robotcub.org.

VII. ACKNOWLEDGMENTS

Work partially supported by EU Project IST-2004-004370 ROBOTCUB and by the FCT Programa Operacional Sociedade de Informação (POSI) in the frame of QCA III.

REFERENCES

- [1] Giulio Sandini, Giorgio Metta, and David Vernon. Robotcub: An open framework for research in embodied cognition. *International Journal of Humanoid Robotics*, 8(2), November 2004.
- [2] Alvin R. Tilley. *The Measure of Man and Woman: Human Factors in Design*. Henry Dreyfuss, 2001.
- [3] L. Geppert. Qrio, the robot that could. *IEEE Spectrum*, 41(5):34–37, May 2004.
- [4] M. Hirose, Y. Haikawa, T. Takenaka, and K. Hirai. Development of humanoid robot ASIMO. In *Workshop on Exploration towards Humanoid Robot Applications at IROS*, Hawaii, USA, 2001.
- [5] F. Yamasaki, T. Miyashita, T. Matsui, and H. Kitano. PINO the humanoid: A basic architecture. In *Proc. of The Fourth International Workshop on RoboCup*, Melbourne, Australia, August 2000.
- [6] Fujitsu. Humanoid Robot HOAP-2. <http://www.automation.fujitsu.com>, 2003.
- [7] Henry Gray. *Anatomy of the Human Body*. Bartleby.com, <http://www.bartleby.com/107/>, online edition, May 2000.
- [8] Loyola University Chicago. Master muscle list. Technical report, Stritch School of Medicine, 1998.
- [9] ExRx.net. Muscle body map. <http://www.exrx.net/Lists/MMale.html>, 1999.
- [10] Wikipedia. List of muscles of the human body. <http://en.wikipedia.org/>, July 2005.
- [11] Wikipedia. List of bones of the human skeleton. <http://en.wikipedia.org/>, July 2005.
- [12] Miguel Silva. *Human Motion Analysis Using Multibody Dynamics and Optimization Tools*. PhD thesis, Instituto Superior Técnico, Lisboa, Portugal, 2003.
- [13] D. Laananen. Computer simulation of an aircraft seat and occupant in a crash environment. Program som-la/som-ta user manual, US Department of Transportation, Federal Aviation Administration, 1999.
- [14] Vladimir Zatsiorsky. *Kinematics of Human Motion*. Human Kinetics Europe Ltd, 1997.
- [15] Zangemeister and Stark. Active head rotations and eye-head coordination. *Ann N Y Acad Sci*, 374:540–59, 1981.
- [16] Julius Panero and Martin Zelnik. *Human Dimension and Interior Space: A Source Book of Design Reference Standards*. Watson-Guptill Pubs, 1979.
- [17] Raffaele Di Gregorio. Kinematics of the 3-UPU wrist. *Mechanism and Machine Theory*, 28:253–263, 2003.
- [18] Gürsel Alici and Bijan Shirinzadeh. Topology optimisation and singularity analysis of a 3-SPS parallel manipulator with a passive constraining spherical joint. *Mechanism and Machine Theory*, 39:215–235, 2004.
- [19] Raffaele Di Gregorio. Statics and singularity loci of the 3-UPU wrist. *IEEE Transactions on Robotics*, 20(4), 2004.
- [20] Faulhaber. DC-Motors. www.faulhaber-group.com, 2005.
- [21] Ptgrey. Firewire cameras. www.ptgrey.com, 2005.